

Guidance notes on pedal car construction

Introduction

Pedal cars can be built using parts of old bicycles of any size or type. There are plenty of bikes to be had at the local tip or car boot sales for a small amount of cash, if you look. BMX bikes are best for making pedal cars, but not essential.

Chassis Design

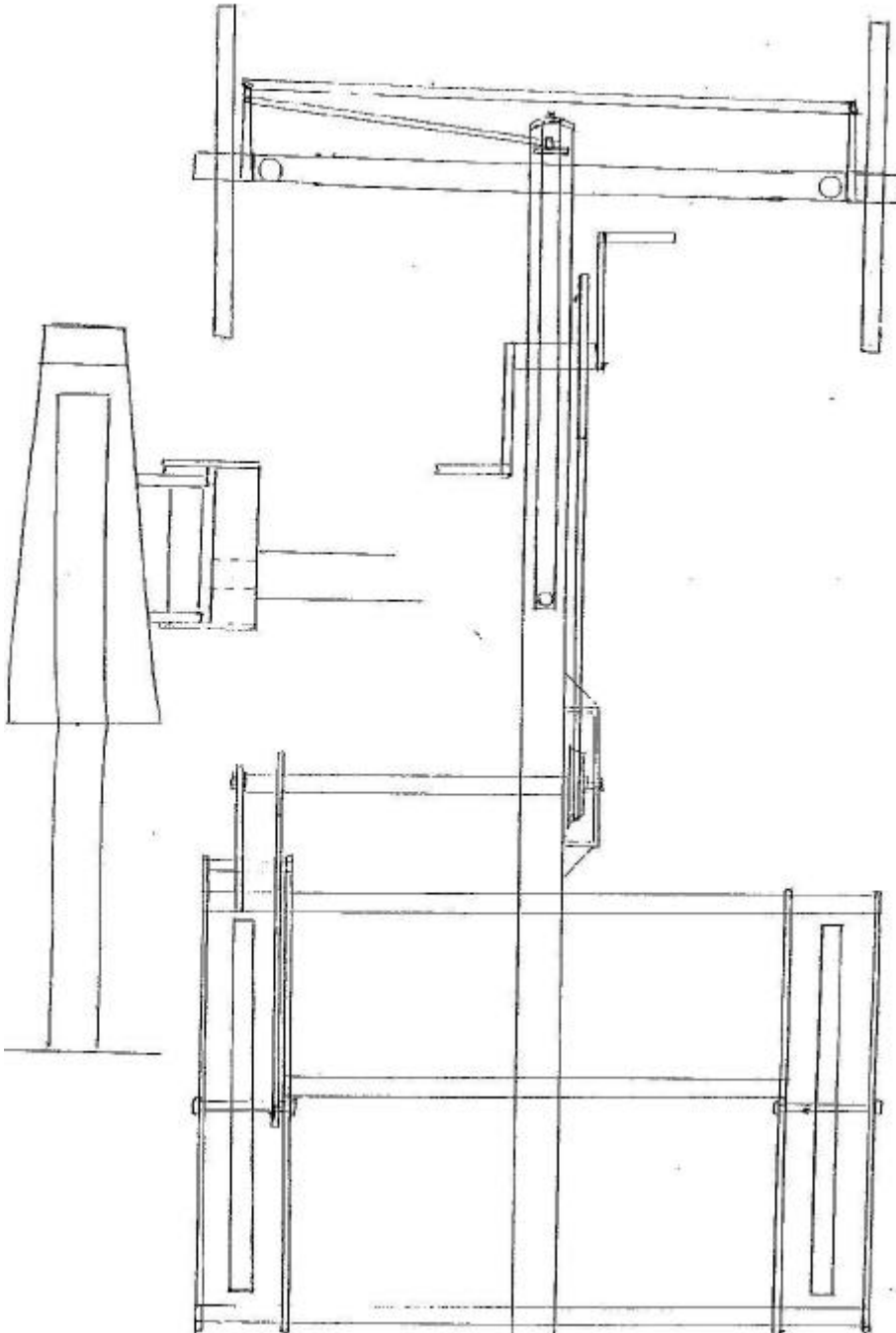

The best way to design a frame is to sit on the garage floor. With legs outstretched, mark out with some chalk where the base of the seat is to go and the furthest point to which your legs will reach.

Measure back from your foot, mark the length of a pedal crank (170mm) and this is the point to place the centre of the pedal car's bottom bracket shell. Allow a couple of inches (50mm) for seat padding and this is the seat back position.

If you now draw a straight line between your two marks and parallel lines 500mm either side, then these are the limits of the car as it begins to take shape. With the axle drawn in, the position of the front wheels can also be determined. The best place for the rear wheels is behind the rear seat line.

Having established the basic positions of the wheels, the builder needs to decide whether to have a rear axle or not, and whether the wheels will be supported by forks like a cycle, or mounted on a hub like a car.

With a rear axle, the chain may simply be passed under the seat to a drive cog on the axle. If only one of the rear wheels is to be driven,

then some provision will have to be made for transferring the drive from the centre line to the driven rear wheel. Since most courses are clockwise in direction, then the driven wheel will be on the outside (left rear wheel) or the rear of the car can be made with the rear end of two bicycles. Cut the down tube just in front of the pedal crank, and cut the top tube off at the pedal post. This gives you the rear triangle to take the wheel, brakes and means to drive one or both rear wheels. Of course you will need to do this twice!

In respect of the wheels, the forks give more support than the hub, but the hub saves weight. Wheels that will take side load are essential. BMX wheels for example, not plastic.

The most convenient height for the chassis would be the same as the wheel centres, this would allow for the axle stubs to be mounted at chassis level. However, with a maximum wheel diameter of 560mm this leaves

only 280mm for the pedal crank arms, the heel of the foot and 25mm clearance. It will therefore be found that the pedal crank will have to be mounted at a height of around 300mm above ground level. The two simplest alternatives then are to mount the pedal crank above the chassis line or mount the wheels below. (Figure 2)

At this point I should explain the reason for only one central spine to the chassis. Whilst they have a certain amount of success, the one problem encountered with a parallel chassis frame is that it does not allow for flexing. This means there is a tendency on fast corners for the inside wheels to lift off the ground. With just one central spine, however, there is sufficient flex in the chassis to keep all four wheels on the ground. The centre spine can be made using the pedal crank or bottom bracket with the pedal crank in it, using a down tube and crank from another bike. This goes forward to take the front axle.

Seat

All the power pushed into the pedal has to be countered by the seat and therefore its strength is vital. There is probably much to be said for building the seat and designing the car around it. It should be high enough in the back to support the shoulders.

In a team of unequal sized drivers, there may be a case for installing an adjustable seat based on a car seat sub-frame. However, it may be more practical to equip the shortest driver with a cushion strapped to their back!

Steering

The way in which the front wheels are attached to the frame will, of course, be dictated by the way in which they are supported. There are basically two ways in which this may be done.

The first method is to support the wheel by means of a stub axle from one side of the wheel only. This method is perhaps the most elegant but inevitably weaker way than the second method of supporting on both sides by means of forks. (Figure 3) These could be forks from two bicycles cut down.

For anyone with limited machining facilities, I would suggest the 'forks method' of supporting the wheel is the one to go for. The next decision is the means by which the wheel is 'hinged' to the frame. In the case of the one-sided hub arrangement, then this swivel would be incorporated into the hub/axle. In the case of the 'forks' arrangement, the forks themselves can be

FIGURE 2



FIGURE 3

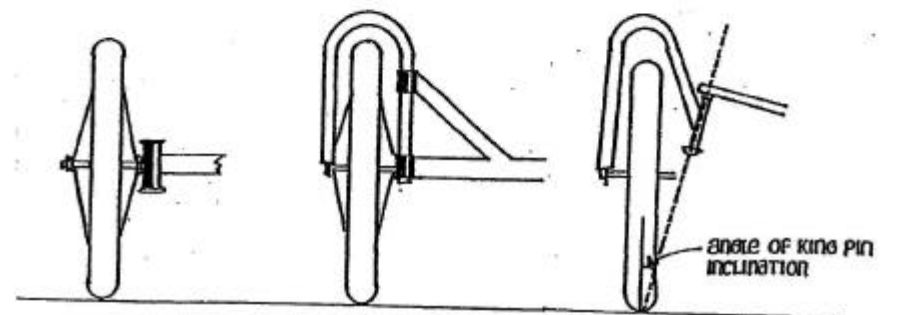
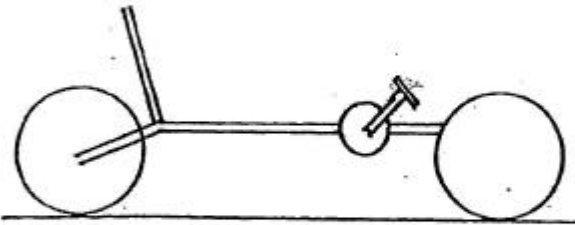

FIGURE 4
PRINCIPLE OF BOCKERMAN STEERING

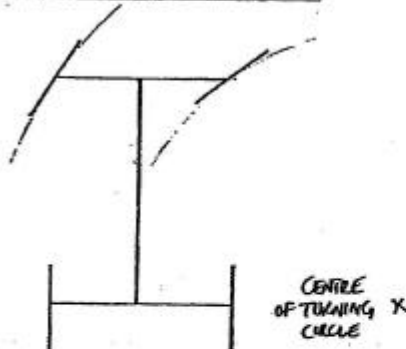

FIGURE 5

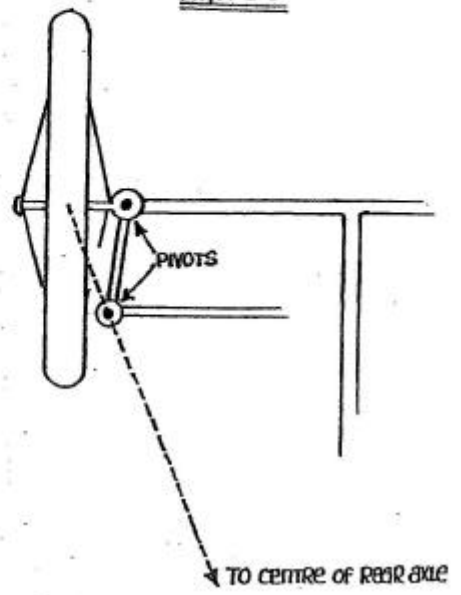
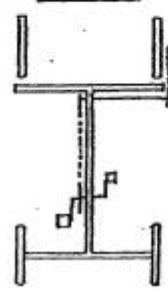

FIGURE 6



attached to the frame via two stem heads from two bicycles.

The next principal is to grasp the Ackerman steering. From the illustration in Figure 4 you will see that the only time the front wheels should be parallel is when they are pointing dead ahead. When they are turning into a corner they should turn by different amounts, the sharper the corner, the greater the difference with each wheel following a different arc. Fortunately, the way this wheel alignment is achieved is straight forward. The first method is one adopted on soap-box carts with the front axle swivelling about the central chassis.

The second and more convenient method is by the use of track rods. The angles of attachments are calculated as follows. (Figure 5) Begin by drawing a straight line between the point at which the front wheel touches the ground and the centre of the rear axle. Repeat this process for the opposite side. Selecting a point 150mm or so back down these lines will be the point at which the steering would be linked. If arms are now attached to the forks which terminate at these points, they may be linked together with swivels at each end and the wheels should now stay in track.

All that now remains is to design some means of moving the track control arm from side to side and the steering will be almost complete. This is normally achieved by means of a steering column held in a cycle drop tube. The steering column has an arm attached at 90 degrees. The length of this arm will decide the steering ratio and is the final variable in the whole geometry. Trial and error will be the simplest way of deciding on the final arrangement, but as a guide it will be found that 100mm track rod ends and a 100mm offset on the steering column, will be a good starting point for further experiment.

Transmission

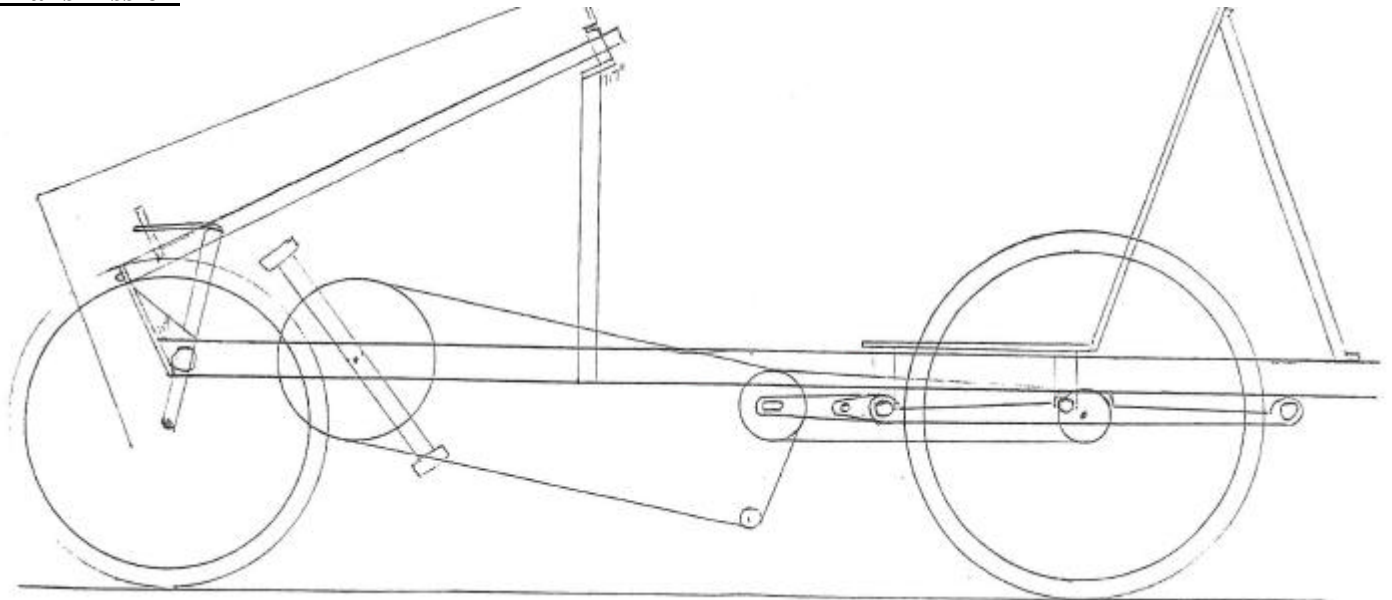

As mentioned earlier, there are two basic ways in which to arrange the transmission for your car. The first is to use a rear axle with a centrally located cog which accepts its drive directly from the front sprocket. Although it may need some form of jockey wheel to guide it beneath the seat and take up the tension in a long chain, it is a direct, and therefore an efficient means of getting power to the back wheels. The lucky scavenger may even be able to find an adult sized rear axle from a tricycle, which will incorporate a differential and frequently a three-speed or even derailleur type gear attached.

The next and more popular layout is to use a lay shaft to transfer drive from the centre to the outside of the car. (Figure 6) A front chain sprocket drives a chain to a five-speed freewheel and a derailleur located below and in front of the seat. The freewheel is attached to one end of a shaft as a cog attached in line with the rear wheel. A simpler and equally effective arrangement is to have a lay shaft with fixed cogs at each end, but utilise a Sturmey three-speed hub in the driven wheel. A chain between these completes the drive mechanism. All that remains then is to couple the gear changing to a selector.

Bodywork, Brakes, etc

A certain amount of bodywork must cover the front and sides of the car. There must be sufficient panelling to allow the car number to be clearly displayed front and back. Design is purely down to the individual and original ideas are always welcome, but NO DANGEROUSLY PROTRUDING PARTS due to safety issues.

Efficient braking is essential and the most popular arrangement is the use of cycle calliper brakes mounted to both rear wheels. The brake levers are mounted on the handlebars with the shortest possible run of cable between levers and brakes securely attached to the frame. In some cases it may be worth while having the brakes operate on the front wheels, but only if they can be fitted successfully.